

BACKLIT LED FLAT PANEL

PFX-5108

PARAFLEX
Fast Flexible Focused Lighting

PROJECT

DATE

TYPE

NOTES

Dream Panels are commercial luminaires utilizing an advanced LED optical system to deliver superior lighting performance. They achieve high uniformity, DLC PREMIUM energy efficiency and reduced glare in typical T-bar grid ceiling applications.

Our state-of-the-art backlit LED technology utilizes PMMA lensing over the LEDs which will not discolor over time. The need for a light guide is eliminated, thus increasing photometric performance while keeping costs competitive. Combined with the rigid back enclosure that prevents warping in application, this luminaire is designed for worry-free longevity and reliability. Available with factory installed battery backup for 90 minutes emergency egress illumination.

SPECIFICATIONS

CONSTRUCTION

- Aluminum frame in white finish, steel die-formed back enclosure

OPTICS

- PMMA lenses over LEDs, PS diffuser
- SDCM < 5
- UGR < 22
- 120° Beam angle

ELECTRICAL

- 0-10VDC Dimming (10%-100%)

INSTALLATION

- Recessed in T-bar grid ceiling with integral earthquake clips for secure attachment
- Surface mount and suspension mount cable kit accessories available

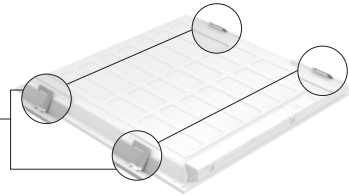

WARRANTY

- 5 Year



CERTIFICATIONS

- UL Listed for Damp Locations
- IC Rated for insulated ceilings
- RoHS, FCC
- DLC PREMIUM
- -20°C to 43°C (4°F to 110°F)

QUICKSHIP ORDERING INFORMATION

Catalog #	Size	CCT	Nominal Lumens	Watts	LPW	CRI	Voltage	DLC	Weight	Qty/ Carton	Pallet Qty.
5108	2' x 2'	4000K	3825	30	127.5	80	120-347VAC	PREMIUM	5.2 lbs	2	72
	2' x 2'	4000K	3825	30	127.5	80	120-277VAC	PREMIUM	5.2 lbs	2	72
	2' x 4'	5000K	5100	40	127.5	80	120-277VAC	PREMIUM	9.2 lbs	2	44
	2' x 4'	3500K	6250	50	125	80	120-277VAC	PREMIUM	9.2 lbs	2	44
	2' x 4'	4000K	6375	50	127.5	80	120-277VAC	PREMIUM	9.2 lbs	2	44

BACKLIT LED FLAT PANEL

PROJECT

DATE

TYPE

NOTES

QUICKSHIP EMERGENCY EGRESS MODELS

Catalog #	Size	CCT	Emergency Lumens	AC Lumens	Watts	LPW	CRI	Voltage	DLC	Weight	Qty/ Carton
5108	2' x 2'	4000K	1515	4590	36	127.5	80	120-277VAC	STANDARD	11 lbs	1
	2' x 4'	4000K	1530	6375	50	127.5	80	120-277VAC	STANDARD	16 lbs	1

Pallet Qty. for 2x2: 32, 2x4: 16

Note: Factory installed 12W battery backup provides 90 minutes of illumination when AC power is removed

MOUNTING ACCESSORIES

SURFACE MOUNT KITS

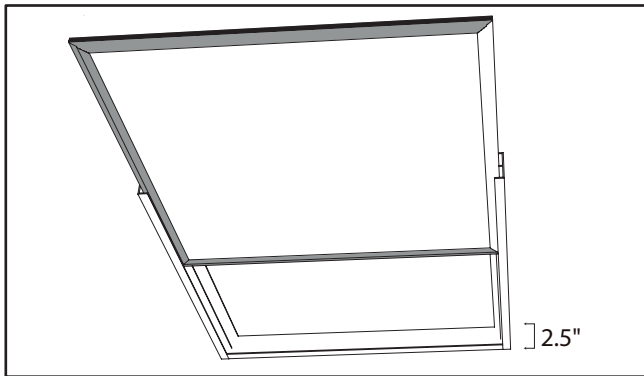

7503 2x2 Surface Mount Kit, White

7504 2x4 Surface Mount Kit, White

BACKLIT LED FLAT PANEL

PROJECT

DATE

TYPE

NOTES

SUSPENSION CABLE MOUNT KITS

(Max. Adjustment Range: 3.9 Feet; Min. Adjustment Range: 0.6 Feet)

1X4 Kits

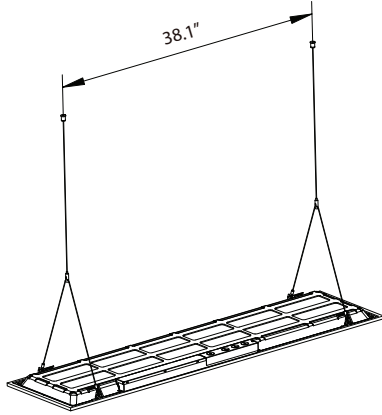

7501 2-Cable Kit

2X2 Kits

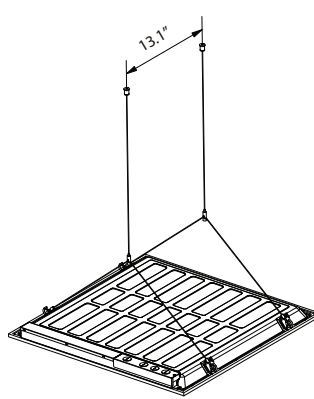

7501 2-Cable Kit

2X4 Kits

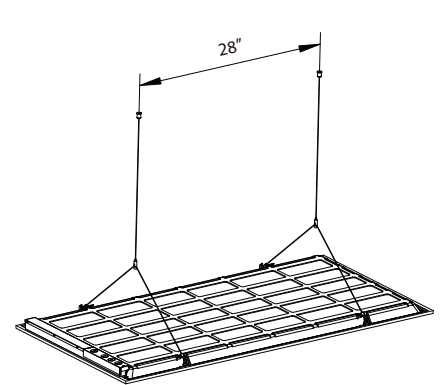

7501 2-Cable Kit

38.1" 10.5"

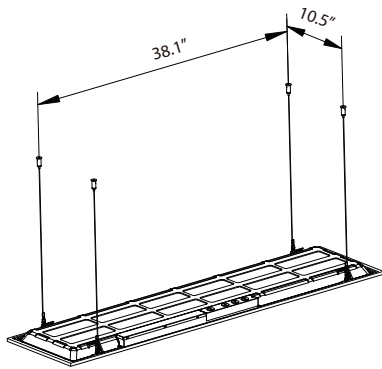

7502 4-Cable Kit

22.3" 13.1"

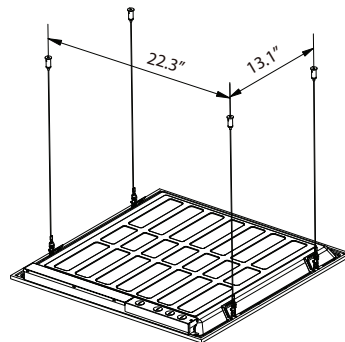

7502 4-Cable Kit

28" 22.3"

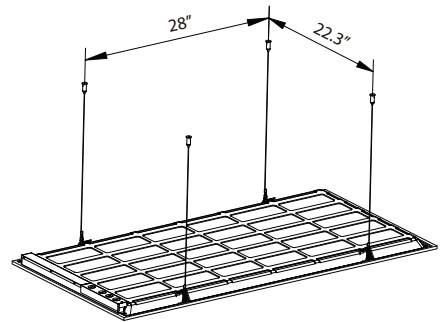

7502 4-Cable Kit

DIMENSIONS

2x4



2x2

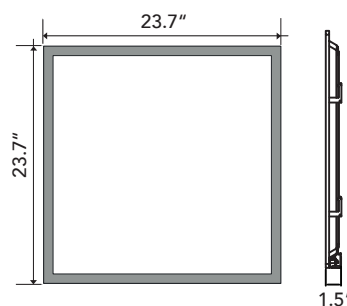

PHOTOMETRY

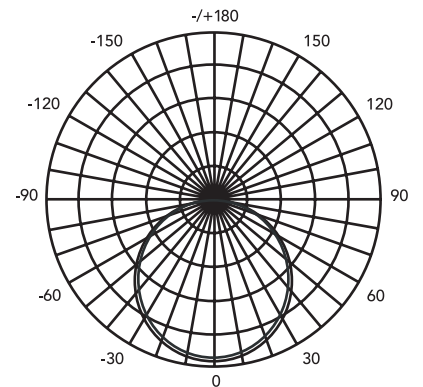

AVERAGE BEAM ANGLE (50%) : 114.3 DEG

LAMBERTIAN